

SONY



BVM-E250A / BVM-E170A

Professional OLED Master Monitors

BVM-F250A / BVM-F170A

Professional OLED Master Monitors

PVM-A250 / PVM-A170 / PVM-741

Professional OLED Picture Monitors



BVM-E250A / BVM-E170A



BVM-F250A / BVM-F170A



PVM-A250 / PVM-A170 / PVM-741

TRIMASTER EL

TRIMASTER EL

- Evolution of Viewing Angles

Continuing enhancement to meet critical user expectations

Since their market debut, TRIMASTER EL™ OLED (organic light-emitting diode) monitors have proved extremely popular, and are now recognized as a de facto standard. As well as offering characteristics superior to CRT monitors, TRIMASTER EL monitors continually evolve to meet the expectations of critical users who demand professional-quality picture performance.

These ongoing improvements include the innovation of wider viewing angles, featured in the TRIMASTER EL OLED A Series: BVM-E250A, BVM-E170A, BVM-F250A, BVM-F170A - master monitors, and PVM-A250, PVM-A170 - picture monitors.

This improvement reduces color shift by half*¹ when compared with their predecessor models, offering the industry-leading wide viewing angles in the professional flat panel market. And it enables group monitoring – for example, video engineers or colorists can view the display properly from many different angles – and hence allows more efficient content creation activities.

Two of these new models offer additional benefits. The PVM-A250 and PVM-A170 are equipped with a variety of convenient features including waveform capabilities, vector scope, closed caption display, and camera focus in color.

Furthermore, the PVM-A250 and PVM-A170 monitors with camera-linkage functions*² provide the convenience of working efficiency both in the field and in the post-process. Now you can bring PVM OLED quality imaging with you, anytime, anywhere.

Designed for every professional need, it's time you experienced the immense value of new TRIMASTER EL monitors.

*¹ Sony's measurement. Results may differ between monitors.
*² Supported with V1.1.



Predecessor models

Front view

The new "A-Series"

* Simulated images

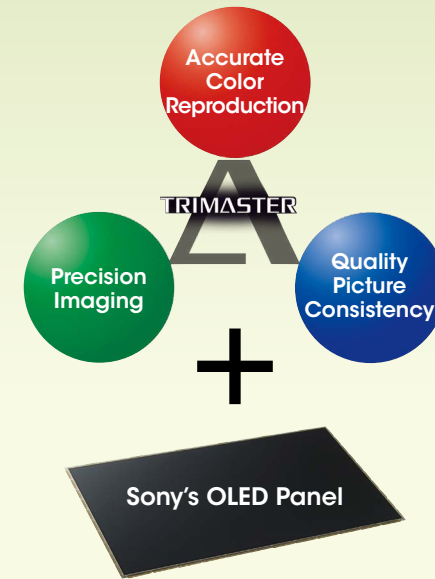

TRIMASTER EL

TRIMASTER™ Technology is a design architecture used to elicit the full performance capabilities of professional flat-panel displays. It comprises the core technologies that enable the highest level of color accuracy, precision imaging, and picture-quality consistency.

EL (Electro-Luminescence) is an ideal self-emission display device with a wide dynamic range and high picture quality. By refining TRIMASTER technology with the new EL device, Sony effectively boosts the performance expectations of the professional industry.

Reference Monitor

BVM-E Series



BVM-F Series



Professional Display Engine

12 bit engine



Digital Cinema Features

- 2K input (2048 x 1080, XYZ)
- 2048 image slide
- User LUT
- ASC CDL
- S-Log gamma
- P&P (Wipe, Butterfly, Blending)
- Gamut error display
- etc.

BVM Advanced Functions

- Channel configuration x 30
- Interlace display
- HD frame capture
- Pixel zoom
- Copy function
- 3D analysis (BKM-250TG)
- Closed Caption (BKM-244CC)
- 24 PsF -> 72 Hz display, etc.
- Option port x 4 (BKM x 6 selection)
- Dual Link (BKM)
- DisplayPort x 1

Standard Features

- 3G-SDI (x2)
- RGB 4:4:4
- HDMI
- Auto White Adjustment
- Time code
- Audio Level Meter*2
- DC Operation (17")

Picture Monitor

PVM Series



Standard Engine

10 bit engine

PVM Features

- Waveform monitor, Vector scope
- DC12V operation for PVM-A170/741
- Dual link HD-SDI*1
- User preset*1
- Closed caption
- Camera metadata*1
- 2K input (2048 x 1080)*1
- P&P (S by S, Wipe, Blending)*1
- Yoke mount support*1

*1 PVM-A250 and PVM-A170 only. Other than the yoke mount support, these functions are supported with V1.1. *2 Optional board required for BVM monitors.

TRIMASTER EL – RGB 10-bit, Full HD

- Sony's unique Super Top Emission technology
- Deep black with wide dynamic range
- Quick response with virtually no motion blur
- Wide color gamut and accurate color reproduction

* 623.4 mm, and 419.7 mm (respectively), measured diagonally.



TRIMASTER EL – Self-emitting Display Device

TRIMASTER EL creates light by recombining an electron and a hole within certain organic materials. The process of emitting light is extremely efficient when compared to other technologies currently used for display. Its organic materials react to the control of the electrical current immediately, and do not emit light in the absence of an electrical current. In this way, the OLED display panel features superb black performance and quick response to fast-motion pictures. In addition, Sony's OLED display panel delivers a wider color gamut.

Super Top Emission Technology

Sony's Super Top Emission OLED panel is designed to deliver light emission with the TFT layer on the rear side of the panel. Therefore, the top emission structure offers more efficient light emission than is typical with bottom emission structures where TFT layers are placed on the front side of the panel, limiting the light-emission aperture.

This Super Top Emission technology has a micro-cavity structure which incorporates color filters. This cavity structure uses an optical resonance effect to enhance color purity and improve light-emission efficiency. In addition, the color filter of each RGB also enhances the color purity of emitted light, and reduces ambient light reflection.

Sony's Super Top Emission OLED panel is completely sealed by a glass substrate, and the electroluminescent layer is fully isolated from outside air and moisture. This contributes to stability and reliability.

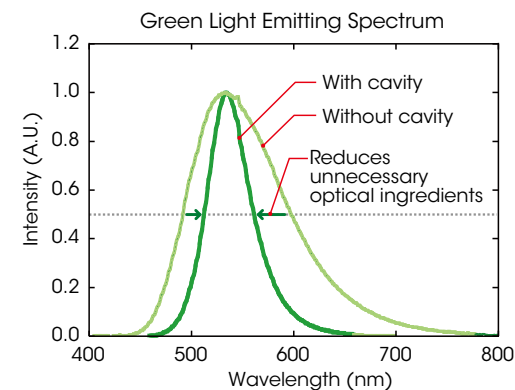
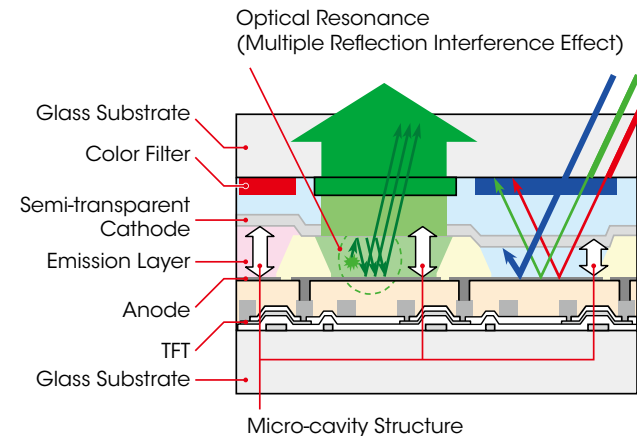

The TRIMASTER EL processor - Dedicated to eliciting full performance.

- Accurate signal processing across all signal levels
- Accurate gamma control
- Superb uniformity control



Dedicated TRIMASTER EL Processor*

The BVM-E, BVM-F, and PVM Series of OLED monitors incorporate OLED-dedicated signal processors to elicit and maximize OLED panel performance. This technology allows these TRIMASTER EL monitors to provide the level of performance required for critical imaging. These processors accurately control gamma and uniformity, and deliver precision stability control.

* The PVM-741 is equipped with a different processing technology (ChromaTRU™).

Accurate gamma control

Since TRIMASTER EL panel can display a deeper black than any other display device, the TRIMASTER EL processor controls gamma accuracy (black reproduction) by increased signal processing bit depth.

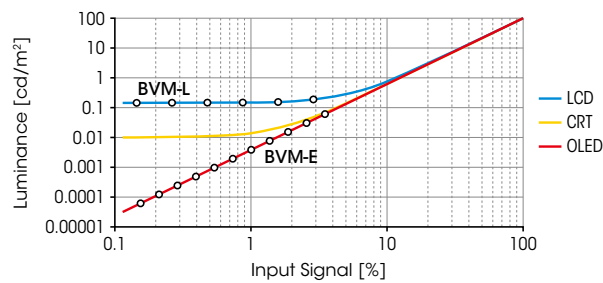

Superb uniformity control

TRIMASTER EL processor offers superb uniformity across all signal levels at every point of the screen. At the factory, OLED-panel uniformity is precisely measured and corrected using a proprietary RGB LUT (look-up table) adjustment system.

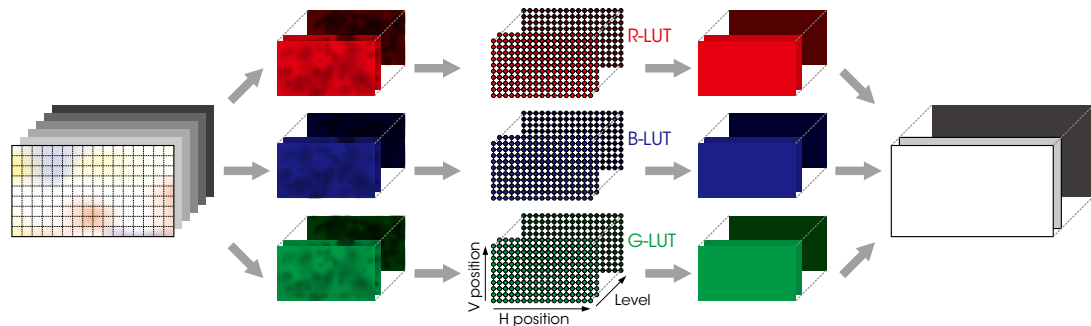

Accurate Black Reproduction

A key advantage of TRIMASTER EL is the fact that each pixel can be turned completely off. No other display technology is able to offer this. LCD either raises black luminance due to intrinsic light leakage, or reduces black luminance with artificial local dimming technologies. CRT always applies a bias voltage to place the gun at the proper operating level. All of these display devices have some limitation in accuracy of black reproduction. In comparison, TRIMASTER EL is capable of reproducing accurate black with each individual pixel, enabling users to evaluate each picture image faithfully to the signal.

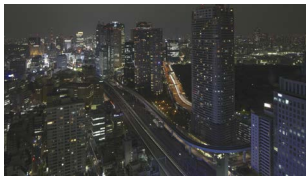

LCD



TRIMASTER EL

* Simulated images

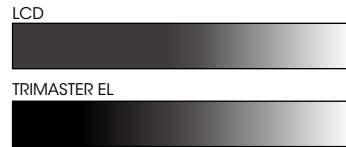
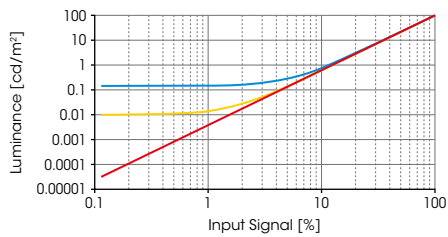

Gray scale images corresponding to the input signal

* Gray scales are simulated images.

Quick Response with Virtually No Motion Blur

The TRIMASTER EL gray-to-gray switching speed (measured in microseconds, μs) is much faster than that of the LCD (measured in milliseconds, ms). * This fast response benefits a variety of applications and uses. For example, in sports broadcasting, when camera pans would become blurred with an LCD, they remain sharp and clear with OLED. And with moving titles or graphics, when text can be difficult to read on an LCD, OLED displays clear text, regardless of speed or direction.

* Sony's test results.

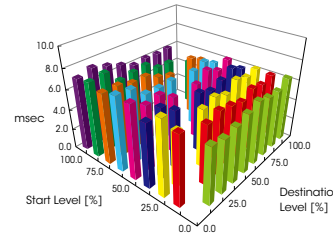

LCD

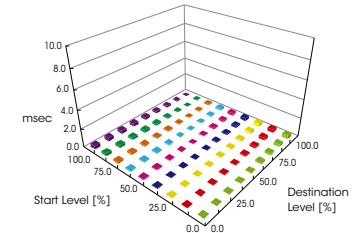

TRIMASTER EL



LCD



TRIMASTER EL

* Simulated images

Accurate Color Reproduction

Sony's Super Top Emission technology not only offers a wide color gamut with its purity of the three primary colors, but also maintains this wide color gamut throughout the entire luminance range. While all other display devices have limitations in reproducing accurate colors, especially in the low signal levels, TRIMASTER EL system is truly an ideal display device for picture evaluation. With OLED, users see the details in the blacks, and see the colors as well.

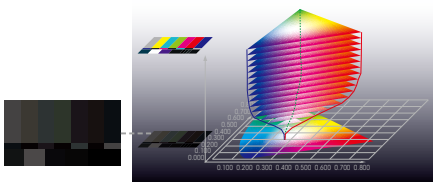

LCD

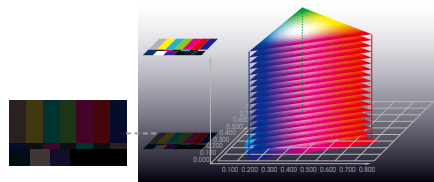

TRIMASTER EL

* Color gamut images based on Sony's test results

Precision Imaging without Artifact

TRIMASTER EL monitors* incorporate the motion adaptive I/P conversion method, which detects information from multiple present and past fields. This is superior to conventional technology, which generally uses motion detection in fewer fields.

With this technology, TRIMASTER EL monitors reproduce video signals accurately without artifacts. You'll appreciate the difference immediately – for example, when there's zero tolerance for failure in shooting, you can be confident of fine patterns or delicate commercial logos.

* BVM-E / BVM-F only.



Conventional technology

TRIMASTER EL

* Simulated images

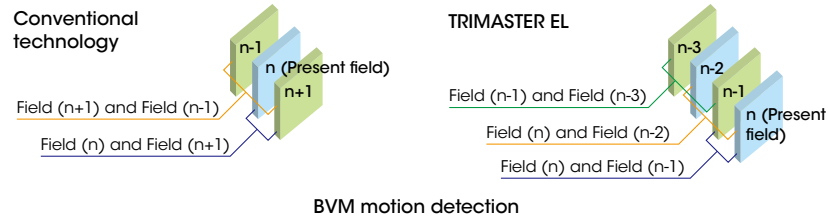

Consistency/Repeatability

The performance of every TRIMASTER EL monitor is precisely adjusted and inspected on gamma, white balance, uniformity, etc., by a highly-robotized system and by professionally trained human eye at the final stage of manufacture prior to shipping. This quality control process provides substantial consistency and uniformity among TRIMASTER EL monitors.

In addition, color reproduction of BVM monitor can easily and accurately be duplicated to other BVM monitors using the Memory Stick™ copy function. Color reproduction of every monitor is matched to the extreme, regardless of their location.



Conventional technology

TRIMASTER EL

* Simulated images

Stability

TRIMASTER EL monitors are designed to control pixel-by-pixel light emission of the OLED panel. This system ensures emission stability over a long duration. You can use TRIMASTER monitors continuously over time with confidence.

In addition, Sony's Super Top Emission OLED panel is completely sealed by a glass substrate, and the electroluminescent layer is fully isolated from outside air and moisture. This also contributes to stability and reliability. TRIMASTER EL monitors can offer higher performance in terms of luminance and white balance than typical reference monitors.



Conventional technology



TRIMASTER EL

* Simulated images

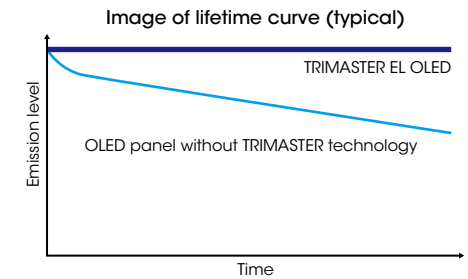

* Simulated image



Pure Solid Structure



Monitors adjustment / inspection

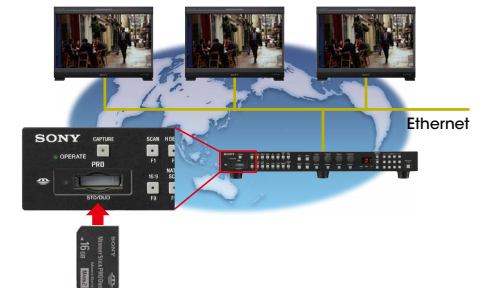

OLED Master Monitor For Critical Picture Evaluation

BVM-E Series



BVM-E250A



BVM-E170A

BVM-F Series



BVM-F250A



BVM-F170A

Professional Display Engine

The high-precision signal processing engine has been developed to fulfill the master monitor criteria and is optimized to maximize OLED panel performance. This engine incorporates 12-bit output accuracy at each process, and provides both a high quality I/P conversion algorithm and a highly accurate color management system.

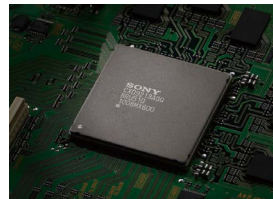

Cutting-edge I/P conversion with low process delay

Sony's original I/P conversion technology used in the BVM Series minimizes processing artifacts found in typical upconversion processes. This has been improved in the BVM-E and BVM-F Series so that an interlaced image is displayed accurately and faithfully.

Nonlinear Cubic Conversion color management

The nonlinear cubic conversion color management system of BVM-E and BVM-F Series master monitors use a unique 3D LUT (look-up table) to accurately reproduce the color gamuts of each broadcast standard such as ITU-R BT.709, EBU, and SMPTE-C phosphor standards. In addition, the OLED's wide color gamut enables D-Cine emulation for digital intermediate work.*

* D-Cine is a color gamut emulating the color gamut described in SMPTE RP 431-2-2007. The chromaticity of the green-red region is not covered in full; however, the color shift is subtle in this region. This feature is supported by the BVM-E Series only.

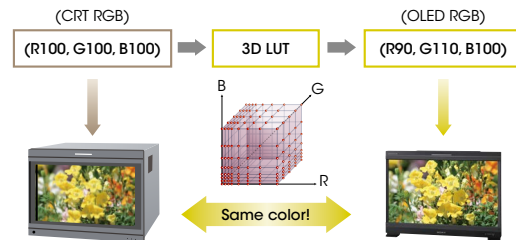
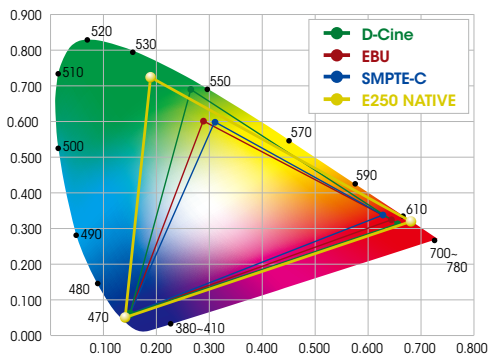

Nonlinear Cubic Conversion color management system

12-bit output accuracy signal processing

The BVM-E and BVM-F Series use a 12-bit display engine, which allows images to be reproduced with high precision for display accuracy.

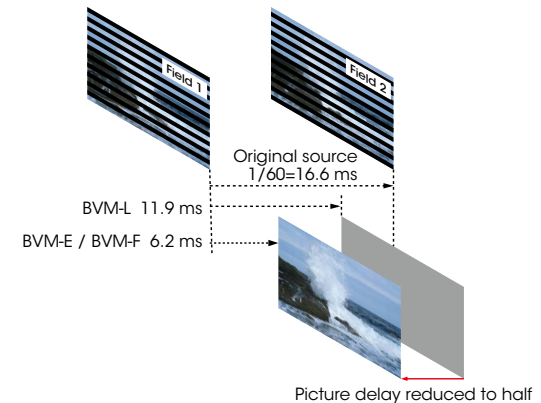

Sophisticated I/P conversion

BVM-E Series Digital Cinema Features

The BVM-E Series – comprising BVM-E250A and BVM-E170A master monitors – offers digital cinema features which are indispensable and ideal for high-quality creative digital cinema onset and post-production workflow.

2K (2048 x 1080, RGB/XYZ) Input

BVM-E250A and BVM-E170A master monitors are capable of 2K (2048 x 1080 resolution, RGB/XYZ) input. The 2K signal is displayed in two ways – as a full 2K image scaled into a full-HD (1920 x 1080) screen, or as a 2K native display with an image-slide function.

2048 Image-slide

The 2048 Image-slide function allows 2K resolution (2048 x 1080 pixels) images to be mapped, pixel-to-pixel, on the full-HD (1920 x 1080 pixels) panel without picture degradation. When the user needs to view the left or right edge of the picture frame, they can scroll the image in a horizontal direction.



S-LOG Gamma

S-LOG gamma is a technique used in Sony's digital cinematography cameras that allows the full latitude of the camera imager to be maintained throughout the production chain. Unlike conventional systems, in which highlight contrast is compressed, S-LOG Gamma logarithmically converts the video signal using characteristics similar to film negatives. This keeps the camera imager dynamic range intact, even in extreme highlight areas. Two display modes are offered:

1) S-LOG Full

This mode displays the full dynamic range of the video signal captured from Sony's digital cinematography cameras.

2) S-LOG Standard

This mode displays image exposure levels at the lower part of the S-LOG gamma signal dynamic range, allowing image areas of regular brightness to be viewed clearly. Higher exposure levels are clipped in this mode.

Gamut Error Display

This function detects irregular signal input. When an irregular signal is detected, these master monitors indicate this with a zebra pattern over the relevant area of the picture.

Gamut Error Display is a convenient feature that instantly alerts viewers to such signals without requiring the use of a waveform monitor.



ASC CDL and User LUT Functions

BVM-E Series monitors support the ASC CDL (American Society of Cinematographers Color Decision List) and User LUT (Look-up Table) to emulate color grading.

Live images from camera onset can be altered after importing an ASC CDL format, and/or previewed using a film print emulation applied to the monitor using Look Creation Workflow.*¹

Furthermore, once ASC CDL and User LUT data are created, all information*² can be saved to Memory Stick media*³ and loaded onto the monitor from the BKM-16R*⁴ controller. Up to five items of ASC CDL and User LUT data can be imported to BVM-E Series monitors, so users can easily compare different color grading (see Look Application Workflow).

These features help with creative decision making and improve workflow between onset and post-production.

*¹ Requires third-party software supporting the BVM-E ASC CDL and User LUT functions.

*² Up to 1,000 data items.

*³ Can use a Memory Stick, Memory Stick PRO™, Memory Stick Duo™, Memory Stick PRO Duo™, or (with optional adaptor) Memory Stick Micro™.

*⁴ Requires the latest version of the BKM-16R with a product code suffix /7 or later.

Look Creation Workflow



Live image from a camera

Look Applying Workflow

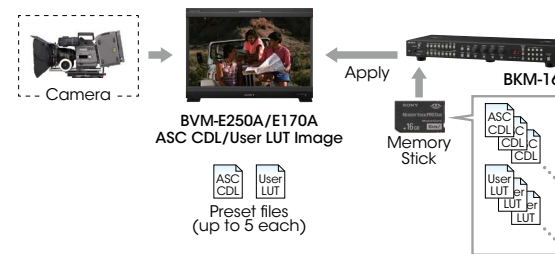

Onset graded image

BVM Advanced Features

Input Versatility

Multi-format signal support

BVM-E and BVM-F Series monitors support various input signals ranging from 720 x 576/50i to 1920 x 1080/50P, 60P, digital cinema (D-Cine) 2048 x 1080/24P*, and numerous computer signals up to 1920 x 1080.

* 2048 x 1080/p signals are supported by the BVM-E Series only.

Standard 3G-SDI inputs plus versatile optional ports

These monitors are equipped with two standard 3G/HV/SD-SDI inputs and an HDMI (HDCP correspondence) input. In addition, four option ports are available. This increases system versatility and allows users to add decoders for signal formats not supported by the supplied inputs, including extra 3G-SDI, HD-SDI, or SD-SDI, and Dual-link HD-SDI, RGB, Y/Cb/Cr, Y/C, and composite signal inputs.

DisplayPort

These monitors are also equipped with a standard DisplayPort.



BVM-E250A Input ports



BVM-E170A Input ports



Standard 3G-SDI interface

Signal-interface Options

BKM-250TG, 3G/HV/SD-SDI Input Adaptor*

- 3G/HV/SD-SDI signal input (x2)
- 3G/HV/SD-SDI monitor output (x2)

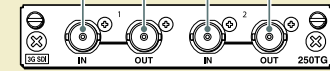

* 3G-SDI, HD-SDI and SD-SDI signals are detected automatically

BKM-243HS, HD-SDI/SD-SDI Input Adaptor*

- HD-SDI/SD-SDI signal input (x2)
- HD-SDI/SD-SDI monitor output (x1)

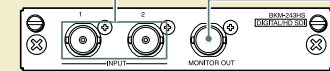

* HD-SDI and SD-SDI signals are detected automatically

BKM-227W, NTSC/PAL Input Adaptor

- Composite input/output (x1)
- Y/C input/output (x1)

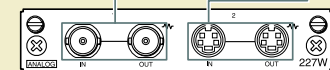

BKM-244CC, HD/SD-SDI Closed Caption Adaptor*

- HD-SDI/SD-SDI signal input (x2)
- HD-SDI/SD-SDI monitor output (x1)

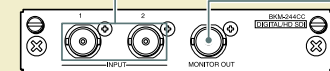

* HD-SDI and SD-SDI signals are detected automatically
* Closed-caption decoders (EIA 608 and EIA 708) are equipped

BKM-229X, Analog Component Adaptor

- RGB, Y/Pb/Pr input (x1)
- EXT SYNC (x1)

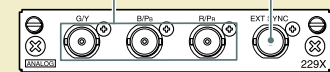

BKM-220D, SD-SDI 4:2:2 Input Adaptor

- SD-SDI signal input (x2)
- SD-SDI monitor output (x1)

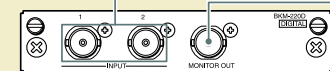

Signal Analyzing Functions

Picture & Picture

The unique Picture & Picture function of the BVM-E and BVM-F Series allows simultaneous display of two input signals on the monitor's screen. This function is extremely convenient for making instant adjustments to two input sources, because there is no need to individually adjust the different characteristics of two monitors. This function comes in handy for adjustments between two cameras, special-effects creation, time-lapse shooting, and computer graphics (CG) work. The BVM-E Series offers four Picture & Picture modes and the BVM-F Series offers side-by-side mode:

Side-by-side

The two picture images are downscaled using a digital filter and displayed side-by-side. This feature is convenient when making white balance adjustments or determining shooting angles between two cameras.



WIPE (BVM-E Series only)

The area of the two pictures to be displayed is selected using a vertical WIPE pattern, which is controlled from the BKM-16R.* This function is useful when picture detail of the two images must be examined on a pixel basis. This is normally used to review still images.



* Requires the latest version of the BKM-16R with a product code suffix /7 or later.

Butterfly (BVM-E Series only)

The two inputs are displayed as line-symmetric images on the left and right halves of the screen. By adjusting the H-position controller, the two images can be moved inward to the middle of the screen. An instant comparison of the moving images can then be made easily and accurately, without the user having to move their eyes.

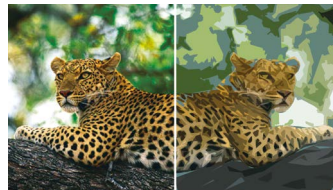

Blending (BVM-E Series only)

The two picture images are overlapped for display, and the mix ratio is adjustable. This function is useful to verify whether a foreground signal is accurately keyed into the background signal, or when combining shoots with live action and computer-generated effects.



Pixel Zoom

Pixel Zoom is a function for magnifying images. A selected area of the displayed picture can be enlarged on a pixel basis, up to eight times in size both vertically and horizontally. Because this function does not use scaling, the desired picture content is magnified and displayed faithfully to the raw input signal. This function is useful when evaluating precise picture edges, such as for chroma keying.

* This function is effective when the input signal is displayed in "Native Scan" mode.

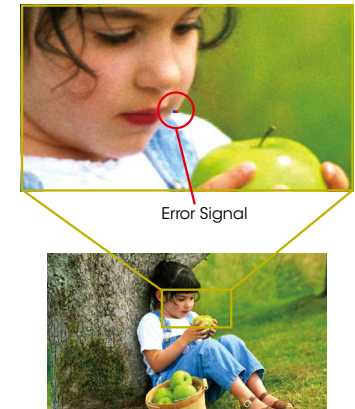

3D Signal Analyzing Functions

By installing the optional BKM-250TG 3G/HD-SDI input adaptor*, the BVM-E and BVM-F Series monitors can support a variety of 3D signal analyses. The 3D signals are displayed in 2D mode.

* "Difference display" function require the BKM-250TG serial No. 7300001 or higher, and other functions require the BKM-250TG serial No. 7100001 or higher.

Difference Display

This function displays the difference between the luminance signal of the left (L) and right (R) images of the 3D signal. When the luminance levels of the two signals are the same, the signals are displayed in gray. When they are different, a monochrome image is displayed according to the variation in luminance. This function is useful for checking the amount of parallax.

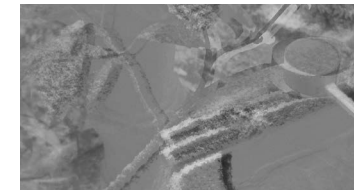

L/R Switch

Left and right signals can be swapped in a moment without inserting black frames, simply by manually pushing a function key. This instant-swap capability enables users to compare the entire images and check for any sense of incongruity or for unnatural images.

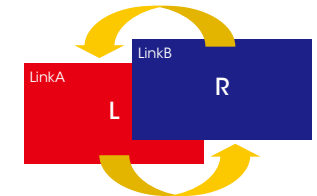

Checker Board Horopter Check Horizontal Flip

Convenient Features

Interlace Display

BVM-E and BVM-F Series monitors offer an Interlace Display feature for 1080i and SD inputs. This lets each BVM-E and BVM-F monitor display these inputs as a true interlace display. As with the Native Scan function, Interlace Display mode offers faithful reproduction of the input signal, and the displayed interlace fields are free from the picture degradation that can occur as a result of typical I/P conversion processes.

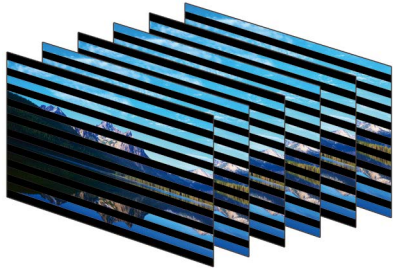

Scan Switch

The Scan Switch function allows switching between under scan (-3%), normal scan (0%), and over scan (mask of the 5% over scan portion in the normal scan).

Native Scan (pixel-to-pixel display)

Conventional flat-panel monitors reproduce images using scaling and I/P conversion due to their fixed pixel counts and progressive scanning processes. The Native Scan function is a unique display mode that reproduces images without changing the input signal's pixel count.

For example, when an SD signal is input, the BVM-E and BVM-F Series monitors will reproduce the image at a picture size of 720 x 487* pixels. For SD inputs the Native Scan function also allows the displayed image size to be doubled to 1440 x 974* by duplicating and doubling each pixel both horizontally and vertically.

* The 525/59.94i signal specified by Rec. ITU-R BT.601.

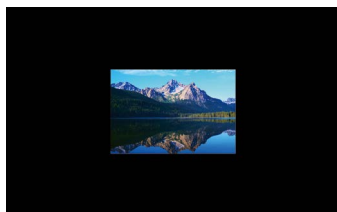

720 x 487 Native Scan

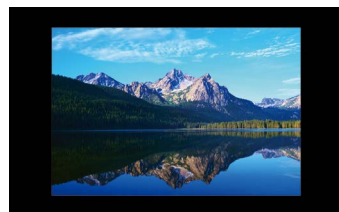

1440 x 974 Native Scan (720 x 487) x 2

HD Frame Capture

The HD Frame Capture function of the BVM-E and BVM-F Series allow a picture frame from the 3G-SDI and HD-SDI input to be captured and saved as a picture file on Memory Stick media.* This picture file can be used as a reference for various purposes; for example, as for picture-tone adjustments between past images and for camera-framing adjustments.

* Memory Stick PRO (High-Speed) / Memory Stick PRO Duo (High-Speed) can be used.

Aspect Correction Mode

PAL and NTSC video systems are all based on rectangular pixels. Display of these formats on a square pixel panel typically distorts the image. The BVM-E and BVM-F Series use a unique process called Aspect Correction which, while still offering native pixel performance, continues to display image geometry correctly. This scaling technique used in BVM-E and BVM-F Series monitors corrects horizontal distortion while keeping the vertical pixel count correctly displayed.

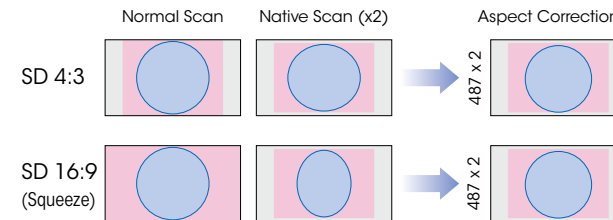

Example of NTSC signal on the 16:9 aspect panel - BVM-E250A

Aspect switch

The aspect ratio can be switched between 4:3, 16:9, 2.39:1, and 1.896:1 depending on the input signal.

* The BVM-F Series monitors support 16:9 and 4:3 only.

16:9	↔	4:3
16:9	↔	2.39:1
1.896:1	↔	2.39:1

Marker settings

BVM-E and BVM-F Series monitors can display various markers, including an aspect marker, safe area marker, and center marker. In addition to this flexible selection of marker types, detailed display settings of each marker are offered. For example, the color, brightness, horizontal/vertical position, and width of aspect markers can all be controlled, while the height and width of safe area markers can be adjusted.

Marker Variation

	Safe Area Marker		Aspect Marker *
	%	Dot (Pixel)	
Selectable Markers	80%, 88%, 90%, 93%, or variable	Flexible	16:9, 15:9, 14:9, 13:9, 4:3, 2.39:1, 2.35:1, 1.896:1, 1.85:1, or 1.66:1
Line Colors	White, Red, Green, Blue, Yellow, Cyan, or Magenta		
Line Width	1 to 5 dots (factory preset at 2 dots)		
Line Luminance	High (bright) or Low (dark)		
Blanking	—		Off: Blanking is released Black: Blanking Half: Half blanking

* The BVM-F Series monitors support Aspect Markers of 16:9 and 4:3 only.

Marker Examples



Aspect Mode: 2.35:1,
Safe Area: Shape A,
Area Size: 80%



Aspect Mode: 14:9,
Safe Area: Shape B,
Area Size: 80%



Aspect Mode: 4:3,
Safe Area: Shape C,
Area Size: 80%

Wide Variety of Functions

The user has a wide variety of over 40 functions to choose from. Each of these can be assigned to any of the 16 function buttons (F1 to F16) on the BKM-16R* controller.

Press ENTER to display the F1 to F8 (or F9 to F16) button assignment on screen.

* Requires the latest version of the BKM-16R with a product code suffix /7 or later.



F9: 16:9
F10: Native Scan
F11: Capture Load
F12: Side by Side
F13: Wipe
F14: Butterfly
F15: Blending
F16: Pixel Zoom

(The next Function display)

* Screen image is simulated

Status Display

Simply assign STATUS to one of the function buttons (F1 to F16) on the BKM-16R* controller.

The user can instantly grasp the whole monitor status and configurations without having to search through menus.

* Requires the latest version of the BKM-16R with a product code suffix /7 or later.



* Screen image is simulated

Modular Monitor Control Unit (BKM-16R*1)

BVM-E and BVM-F Series monitors and their control panels are provided as separate units, allowing greater flexibility for system integration. BVM-E and BVM-F Series monitors incorporate a monitor control unit (the BKM-16R) as an option. The BKM-16R can be attached beneath the monitor using the optional controller attachment stand*2, or connected remotely via an Ethernet cable.

*1 Requires the latest version of the BKM-16R with a product code suffix /7 or later, or the latest version of the BKM-37H, BKM-38H, and BKM-39H with a product code suffix /1 or later.

*2 The BVM-E250A and BVM-F250A use the BKM-37H or BKM-38H attachment stand. The BVM-E170A and BVM-F170A use the BKM-39H attachment stand.



BVM-E250A monitor
BKM-16R monitor control unit
BKM-37H attachment Stand
with tilt function



BVM-E170A monitor
BKM-16R monitor control unit
BKM-39H attachment Stand



BVM-F250A monitor
BKM-16R monitor control unit
BKM-38H attachment Stand

Copy function for monitor setup and adjustment data

The optional BKM-16R control unit includes a Memory Stick slot*1 to save and load monitor configuration and adjustment settings. This is useful for multiple monitor systems, allowing the transfer of one monitor's setup and adjustment data to another.*2

This data can also be transferred via the BVM's Ethernet connection.

*1 Memory Stick, Memory Stick PRO, Memory Stick Duo, Memory Stick PRO Duo, and Memory Stick Micro (an optional adaptor is required) can be used.

*2 Data can be moved between BVM-E and BVM-F Series monitors.

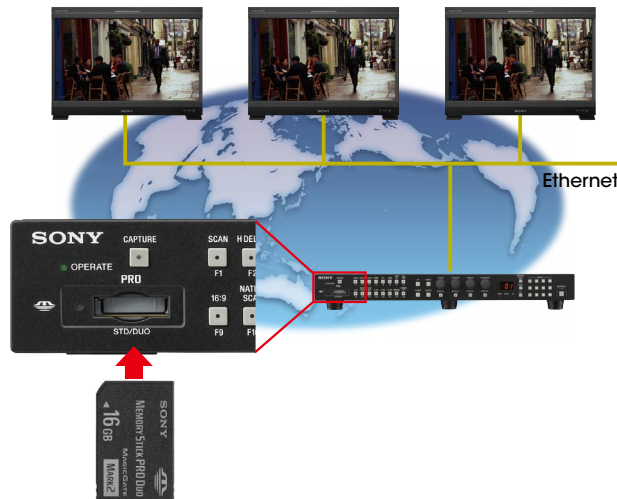

"+12dB Chroma UP" function

A "Chroma UP" button located on the front panel of the BKM-16R allows the chroma level to be boosted by +12 dB.

This is a convenient feature for adjusting camera white balance with a higher degree of accuracy.

Ethernet-based remote control

The BVM-E and BVM-F Series monitors and the BKM-16R Monitor Control Unit are equipped with an Ethernet port, allowing remote control of display parameters across a standard Ethernet connection. One BKM-16R Monitor Control Unit can control up to thirty-two (32) BVM* monitors.

* Includes BVM-A CRT monitors, BVM-L, PVM-L, and BVM-E/-F Series monitors.

BKM-16R Monitor Control Unit

Front panel



Rear panel



Easy Setup and Adjustment

Auto White Adjustment

The BVM-E and BVM-F Series monitors employ a software-based color temperature (white balance) calibration function, which is called "Monitor_AutoWhiteAdjustment". Combined with a PC and commercially available calibration tools*, this function enables simple adjustment of the monitor's white balance.

* Konica Minolta CA-210, CA-310, CS-200, DK-Technologies PM5639/06, X-Rite i1 Pro/i1 Pro2, Photo Research PR-655/670, Klein K-10, and JETI specbos 1211. A connector is required for each color analyzer.

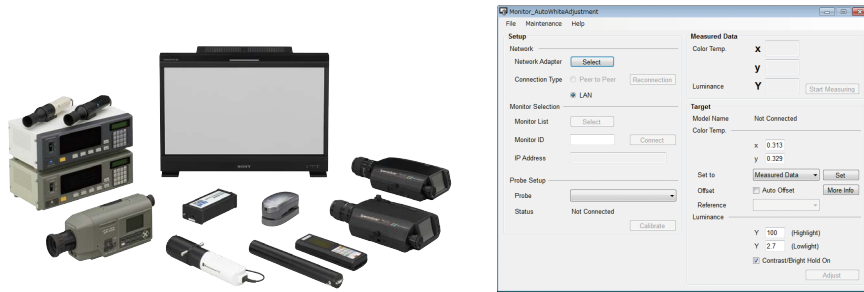

"Monitor_AutoWhiteAdjustment" GUI image

Built-in Color Sensor for Auto White Adjustment

The BVM-E170A and BVM-F170A are equipped with a built-in color sensor, which allows the user to calibrate the monitor's color temperature (white balance) as needed without an external probe. Calibration performance is minimally affected by ambient light. This function ensures color and gamma consistency, and reduces user maintenance tasks.



"Character Off" button

To facilitate parameter adjustments, the On-Screen Menu indication can be taken off the screen, while in Menu mode. The On-Screen Menu indication can be toggled on or off with a simple press of a button on the BKM-16R's front panel.

Auto Chroma / Phase adjustment*

An Auto Chroma / Phase / Matrix setup function is provided on BVM-E and BVM-F Series monitors, which automatically adjusts the monitor's chroma, phase, and matrix using external color bars.

* Supports analog signal inputs only.

DC operation

The BVM-E170A and BVM-F170A can be DC operated. Due to their lightweight and small-size design, with a comparable height to the former 14-inch BVM-CRT monitors, the BVM-E170A and BVM-F170A are ideal for field and OB van applications.

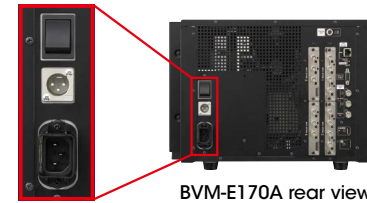

BVM-E170A rear view

Tilt stand for BVM-E250A / F250A



BVM-E250A with the optional BKM-37H* tilt stand

* Requires the latest version of the BKM-37H with a product code suffix /1 or later.

Other features

- VESA™ Mounting (200 x 100 mm pitch)*¹
- EIA 19-inch Standard Rack-mountable*²
- Blue Only
- Mono
- H Delay / V Delay
- NTSC Setup Level (0%, 7.5%)
- Component Level (SMPTE / EBU-N10 or Betacam)
- Aperture
- Serial Remote (Ethernet)
- Parallel Remote (D-sub 9-pin)
- Tally Lamp (Amber)
- EXT Sync (for RGB / YUV)
- Remote Maintenance

*¹ BVM-E250A / BVM-F250A only.

*² BVM-E170A / BVM-F170A only. Mounting brackets are supplied.

OLED Picture Monitor For Critical Picture Viewing

PVM-A Series



PVM-A250



PVM-A170



PVM-741



Lightweight and Slim - Easy to Carry

The PVM-A Series includes the PVM-A250 (25-inch) and PVM-A170 (17-inch) monitors, achieving an industry-leading lightweight and slimline body.*¹ The PVM-A250 weighs 6.1 kg and the PVM-A170 weighs just 4.2 kg, and both are approximately 40% slimmer than previous PVM-41 Series models.

Furthermore, PVM-A Series monitors provide versatility for a wide range of user applications both in the studio and in the field: DC operation*², VESA-mount and yoke-mount holes, and an optional protection kit.*³

These advantages allow the new PVM monitors to be used in a wider range of applications and reduce associated costs. These monitors are ideal for field monitoring and can be installed on a monitor wall or in an OB van. Now users can experience reliable, high-quality OLED monitoring anytime, anywhere.

*¹ Professional broadcast monitors incorporating SDI interface(s) and built-in AC power.
*² The PVM-A250 does not support DC operation.
*³ The PVM-A250, PVM-A170 only.

Viewing Angle Innovation

The PVM-A250 and PVM-A170 incorporate the TRIMASTER EL OLED panel to offer an industry-leading viewing angle compared with other professional flat-panel monitors available on the market. This enables group monitoring – for example, video engineers or colorists can view the display properly from many different angles – and this allows more efficient content creation activities.

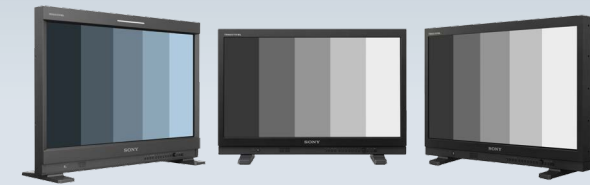

Predecessor models

Front view

PVM-A250 / PVM-A170

* Simulated images

New Design Innovation

As well as offering high performance, both the PVM-A250 and PVM-A170 have a new chassis design that fits portable and field applications. The slim design, new handle, and protected connectors are perfect for rental, on set, and light stand applications.

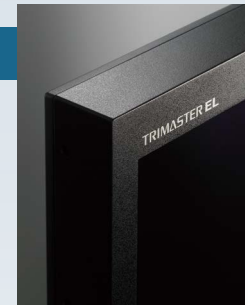

Connector panel



PVM-A250 rear



PVM-A250 side

Groundbreaking Picture Performance with TRIMASTER EL Technologies

Sony's 24.5-inch, 16.5-inch, and 7.4-inch Super Top Emission OLED display panels provide unparalleled black performance, a wide color gamut, and quick pixel response with virtually no motion blur. By combining TRIMASTER EL display panel (Full HD*¹, 10-bit driver) and TRIMASTER EL processing technologies*², the PVM Series of OLED monitors deliver exceptional picture quality never before seen in conventional picture monitors.

*1 The PVM-741 delivers Quarter HD (960 x 540) resolution.
 *2 The PVM-741 is equipped with the ChromaTRU processing technology.



Sony's OLED Full HD, 10-bit

TRIMASTER EL with Full HD* and 10-bit RGB

The PVM-A250 and PVM-A170 OLED panel with Full HD resolution (1920 x 1080) and a 10-bit RGB driver, together with Sony's Super Top Emission OLED display panel, creates lifelike and smoother-than-ever gradation from dark to bright portions of a scene such as in a sunrise or sunset.

* The PVM-741 delivers Quarter HD (960 x 540) resolution.



8-bit (256-levels) image*



10-bit (1024-levels) image*

* Simulated images

Superb Black Performance

Thanks to TRIMASTER EL system, deep blacks can be accurately displayed and the black portion of an image is not degraded.

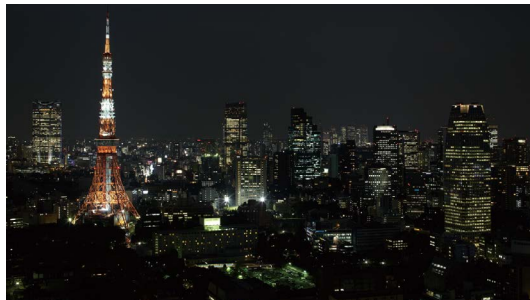

Black performance image

* Simulated images

Wide Color Gamut and High-purity Deep Color Reproduction

TRIMASTER EL technology shows the largest color range of any Sony monitor ever offered. Color standards such as ITU-R BT.709, EBU, and SMPTE-C are displayed more accurately and, if desired, the OLED panel's native color gamut can be displayed. Sony's micro-cavity structure uses an optical resonance effect in combination with accurate color filters to calibrate and stabilize RGB color accuracy. This combination is also effective in reducing ambient light reflection, and consequently deep color reproduction can be achieved without degradation, particularly in bright environments.

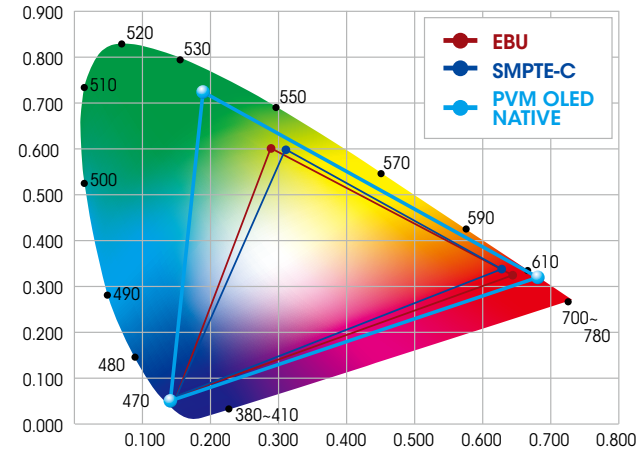

PVM Series OLED monitors color gamut

Lightweight Compact Design and Versatility for a Wide Range of User Applications

Flexible Mounting For Picture Monitoring

PVM-A250 and PVM-A170 monitors incorporate a lightweight, compact body. Their design offers flexibility, and can be adapted according to the application: a desktop unit with standard table feet, or used with an optional SU-561 stand, or without the stand for wall applications. These monitors support VESA mounting with a 100-mm pitch, and EIA 19-inch standard racks. * This allows the monitors to be used for all types of application – desktop editing, office viewing, used on a studio monitor wall, or installed in OB vans.



Optional Protection Kit

This accessory provides an AR-coated protection panel for the PVM-A250 and PVM-A170 monitor, along with corner bumpers to safeguard the monitor from scratches and impact. The benefit of this is significant when renting out these monitors – for example, panel damage is reduced and there is a far lower incidence of panel replacement and downtime during rental cycles.



Yoke-mount and VESA-mount Capability

PVM-A250 and PVM-A170 monitors have screw holes on their side bezels for yoke mounting. This type of mounting is convenient when installing a monitor to a camera crane or monitor stand. There are also VESA-mount 100-mm pitch holes on each monitor's rear panel.



	PVM-A250	PVM-A170
Standard monitor feet	✓	✓
Optional monitor stand	SU-561	SU-561
VESA mounting (100 x 100 mm)	✓	✓
Yoke mounting*	✓	✓
Rack mount (optional)	MB-L22	MB-P17
Protection kit (optional)	BKM-PP25	BKM-PP17

* 3rd vendor yoke mount is required.

User-friendly Operability and UI

A rotary-type switch and seven function-assignable buttons allow users quick and intuitive operation. Operation buttons with LED indicators enable error-free operation, even in dark environments. *



* LED lights can be switched on/off.



Front control panel

Input Versatility

PVM-A Series monitors are equipped with built in standard input interfaces: 3G/HD/SD-SDI (x2), HDMI (HDCP) input (x1), and composite (x1). These monitors*¹ support dual-link HD-SDI to accept up to 1920 x 1080/50p, 60p signals.*² They also support 2048 x 1080/50p, 60p signals.*²

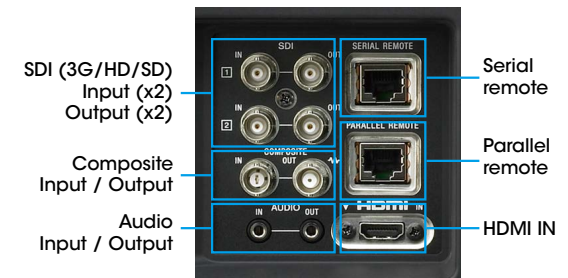

*¹ The PVM-741 does not support dual-link HD-SDI and 2048 signals.

*² Supported with V1.1.

Optimized Low-latency I/P Conversion*

The I/P conversion system delivers automatically optimized signal processing according to input signals with low-latency (less than 0.5 field). This system helps users to edit and monitor for a live production.

* PVM-A250 and PVM-A170 only. PVM-741 is equipped with selectable four I/P modes.

Waveform Monitor and Vector Scope Display

These enable users to monitor sources using the internal waveform and vector scope. These displays also provide some of the same evaluation tools as larger dedicated equipment. Both the waveform monitor and the vector scope offer zoom functions for very precise signal adjustment (from zero to 20% video level). In addition, the waveform monitor includes a line select feature, so users can adjust levels based on individual areas of the screen. Both displays have two-channel audio monitoring. In conjunction with the Picture & Picture function*, the waveform monitor and vector scope display can monitor two camera signals.

* Supported with V1.1.



Waveform monitor

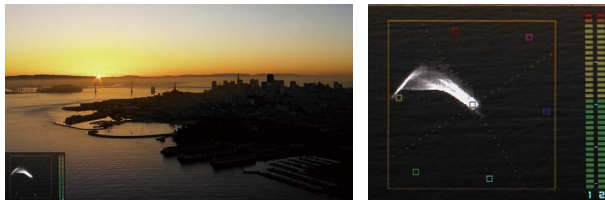

Vector scope

Camera Focus Function

PVM-A Series monitors can control the aperture level of a video signal, and display images on screen with sharpened edges to help camera focus operation. Further to this, the sharpened edges can be displayed in user-selectable colors (white, red, green, blue, and yellow) for more precise focusing.



Camera focus image

Line-doubler Mode* for Field Check

The PVM-A250 and PVM-A170 offer a line-doubler mode which is helpful when checking for line flicker.

* Supported with V1.1.

Auto White Adjustment*¹

PVM-A250, PVM-A170, and PVM-741 monitors employ a software-based color temperature (white balance) calibration function, which is called Monitor_AutoWhiteAdjustment. Combined with a PC and commercially available calibration tools*², this function enables simple adjustment of the monitor's white balance.

*¹ Supported with V1.1.

*² The Konica Minolta CA-210/CA-310/CS-200, DK-Technologies PM5639/06, X-Rite i1 Pro/i1 Pro2, Photo Research PR-655/670, Klein K-10, and JETI specbos 1211.

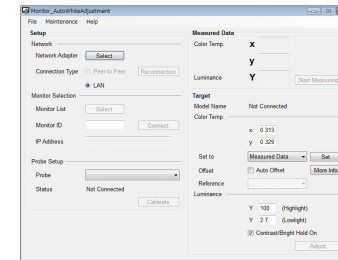

"Monitor_AutoWhiteAdjustment" GUI image

PVM-A250 and PVM-A170 monitors with camera-linkage functions* provide the convenience of working efficiency both in the field and in the post-process. Their functions include camera metadata display and a Picture and Picture function. Also these monitors provide convenient features that save administrative operating costs, including UserPreset, password lock, and a networking upgrade function.*

The PVM-A250 and PVM-A170 offer common user interfaces (UIs), so that users can combine these monitors yet achieve the same functionality and operational familiarity across all display types.

* All functions on this page with an asterisk are supported with V1.1.

Picture & Picture*

The unique Picture & Picture function of the PVM-A250 and PVM-A170 allows simultaneous display of two input signals on the monitor's screen. This function helps with color adjustment and setting of camera frames.

* This function works when synchronous SDI signals are input.

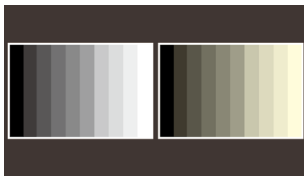

Side-by-side

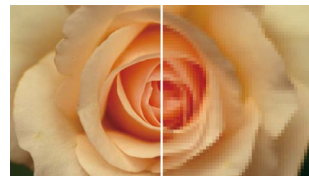

Wipe



Blending



Difference

2K (2048 x 1080) Input and Image-slide*

PVM-A250 and PVM-A170 monitors are capable of 2K (2048 x 1080 resolution) input. The 2K signal is displayed in two ways – as a full 2K image scaled into a full-HD (1920 x 1080) screen, or as a 2K native display with an image-slide function.



Camera Metadata Display Function*¹

PVM-A250 and PVM-A170 monitors can display the camera and lens metadata set of a camera system, according to the SMPTE RDD-18 document for Acquisition Metadata Sets for Video Camera Parameters. Further to this, these monitors also support a subset of Sony's private metadata.*²

*¹ Supported with V1.1.

*² Not all metadata is supported.

Anamorphic Image Conversion*

PVM-A250 and PVM-A170 monitors correctly display horizontally squeezed 3G/HD-SDI signals from an onset camera system. The signals include two major systems: 16:9 1920 x 1080 (1280 x 720) signals and 17:9 2048 x 1080 signals. These signals can be appropriately displayed on the monitor's screen.

* Only 3G/HD-SDI and dual-link HD-SDI are supported.



Native scan image



Normal scan image

Grid Display*

This function displays arbitrary multiple vertical and horizontal lines to help when users check the composition of a picture.

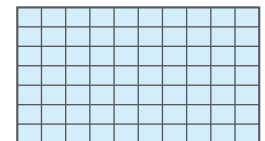

Vertical and horizontal lines

Center Markers*

In addition to a standard Center Marker 1, Center Marker 2 is also available. This second marker enables easier checking of the center portion's focus.



Center marker 1



Center marker 2

Flip Function*

The Flip function turns the reversed image to a normal view, horizontally or vertically.

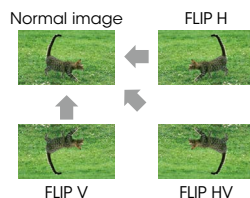

Multiple Monitors Upgrade Utility*

Multiple PVM-A250 and PVM-A170 monitors on the same Ethernet network can be upgraded by simple operation.

Power-on Setting*

This function allows users to select setting data when the monitor starts up; this includes last memory, user preset, and factory preset settings. Users can set the monitor accurately and quickly. This function is very useful for rental equipment.

User Presets*

When multiple users share the same monitor, each user can memorize his/her setting data and retrieve this data whenever required. This frees the user from time-consuming and repetitive setting tasks.

Password Lock for User Preset*

When multiple users share the same monitor, each user can register his/her own password for color temperature and user preset data. This ensures the user correctly recalls previous user preset data, and keeps preset information safe from unauthorized use.

Short-cut to Function Key Configuration*

By simply pressing the function key repeatedly, the user can take a short-cut to the settings menu screen.

USB 2.0 for Power Supply (+5 V, 500 mA)*

The USB 2.0 port can supply 5 V power to third-party devices.

On-screen Tally*

The on-screen tally can display in three colors. The position of the tally display can be changed to either the upper or lower section of the screen.



On-screen tally (upper)



On-screen tally (lower)

Active Format Description (AFD) Function*

PVM-A250 and PVM-A170 monitors read the ancillary data flag on an SDI, and upconvert the SD image to display automatically on the full HD resolution screen. This is achieved by adjusting the resolution and aspect ratio.

* Only SD-SDI signals are supported.

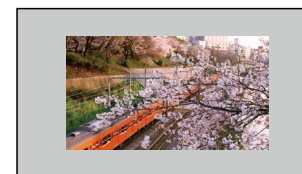

SD image

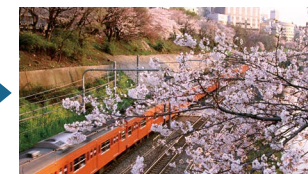

Up-converted image

DC Low Power Indicator*

The power indicator blinks when the DC power supply is low.

* The PVM-A250 does not support a DC power supply.

* All functions on this page with an asterisk are supported with V1.1.

Robust, light-weight, and compact body

Incorporating a light-weight and compact aluminum-diecast body with a detachable AR-coated protection panel, this model is flexible enough to change style according to user requirements.



AR-coated protection panel



PVM-741 installed in the optional MB-531 19" mounting bracket with MB-532 mounting panel

Easy Mounting into A Camera System

With 3/8-inch and 1/4-inch screw holes on its base, the PVM-741 can be installed in a camera system. Also with the supplied arm-mount bracket fixed on the top, these monitors can be installed in a camera arm.



Rear and bottom

1/4 inch hole
3/8 inch hole

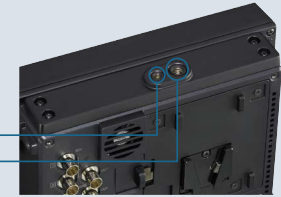

Arm-mount bracket is attached on the top

Retractable Carrying Handle

A retractable carrying handle is provided as a supplied accessory, allowing users to carry these monitors anytime, anywhere.



PVM-741 with carrying handle

ENG Kit VF-510

For use in ENG and EFP field, the optional VF-510 ENG Kit provides a viewing hood, carrying handle, and connector protector.



VF-510 ENG Kit



PVM-741

*Simulated images

Sony's Super-Top-Emission OLED panel with a 10-bit driver
960 x 540 pixels resolution

- Two 3G/HD/SD-SDI and an HDMI input interfaces
- Waveform monitor, Vector scope, Audio level meter, Time code
- Closed caption display
- Camera focus function
- Easy-to-use control panel

PVM-741 features

Camera Focus Function

The PVM-741 can control the aperture level of a video signal, and display images on the screen with sharpened edges to help camera focus operation. Further to this, the sharpened edges can be displayed in user-selectable colors (white, red, green, blue, and yellow) for more precise focusing. This camera focus function can even be enhanced when combined with native scan mode.



Flip function

The PVM-741 monitor has a feature to flip a picture without frame delay, horizontally, vertically, or horizontally and vertically.

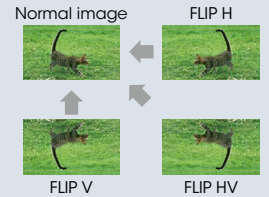

Waveform Monitor and Vector Scope Display

An input signal's waveform and vector scope with an SDI-embedded 2-channel audio level meter can be displayed on screen. Both the waveform monitor and vector scope have various modes, including a zoom function.

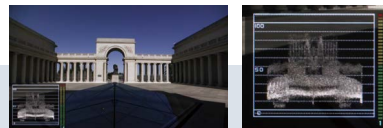

Waveform monitor

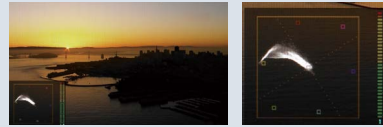

Vector scope

Input versatility

The PVM-741 is equipped with built-in standard input interfaces: 3G/HD/SD-SDI (x2), composite (x1), and HDMI input (x1).



Easy-to-use control panel design



Input selection buttons

Assignable function buttons Default setting;

- F1 (BRIGHTNESS) F2 (CONTRAST)
- F3 (CHROMA) F4 (SCAN)
- F5 (H/V DELAY) F6 (VOLUME)
- F7 (I/P MODE*)

*Picture Delay Minimum Mode

Up/down Volume & Enter/set button

Return button

Menu on/off button

BVM-E / BVM-F Series Signal Formats / Input Adaptors

Input signal	Signal system	Signal format	Standard SDI Input	BKM-220D	BKM-227W	BKM-229X	BKM-243HS BKM-244CC	BKM-250TG
Analog composite	487/59.94i	NTSC			○			
	576/50i	PAL/SECAM			○			
	487/59.94i	PAL-M			○			
Analog Y/C	487/59.94i	NTSC			○			
	576/50i	PAL/SECAM			○			
	487/59.94i	PAL-M			○			
Analog component, RGB	1080/60i*1	Y/Pb/Pr, RGB				○		
	1080/50i				○			
	1080/24PsF*1				○			
	1080/25PsF				○			
	1080/30PsF*1				○			
	1080/24p*1				○			
	1080/25p				○			
	1080/30p*1				○			
	720/60p*1				○			
	720/50p				○			
	576/50i				○			
	487/59.94i				○			
	SD-SDI		720 x 487/59.94i	4:2:2 Y/Cb/Cr	○	○		○
720 x 576/50i		○	○			○	○	
HD-SDI	1920 x 1080/24PsF*1	10 bit 4:2:2 Y/Cb/Cr	○			○	○	
	1920 x 1080/25PsF		○		○	○		
	1920 x 1080/30PsF*1		○		○	○		
	1920 x 1080/24p*1		○		○	○		
	1920 x 1080/25p		○		○	○		
	1920 x 1080/30p*1		○		○	○		
	1920 x 1080/50i		○		○	○		
	1920 x 1080/60i*1		○		○	○		
	1280 x 720/24p*1		○		○	○		
	1280 x 720/25p		○		○	○		
	1280 x 720/30p*1		○		○	○		
	1280 x 720/50p		○		○	○		
	1280 x 720/60p*1		○		○	○		

Input signal	Signal system	Signal format	Standard SDI Input	BKM-220D	BKM-227W	BKM-229X	BKM-243HS BKM-244CC	BKM-250TG	
HD-SDI dual-link	1920 x 1080/24PsF*1	10 bit 4:4:4 Y/Cb/Cr, RGB 12 bit 4:4:4 Y/Cb/Cr, RGB					○*2	○	
	1920 x 1080/25PsF					○*2	○		
	1920 x 1080/30PsF*1					○*2	○		
	1920 x 1080/24p*1					○*2	○		
	1920 x 1080/25p					○*2	○		
	1920 x 1080/30p*1					○*2	○		
	1920 x 1080/50i				○*2	○			
	1920 x 1080/60i*1				○*2	○			
	1920 x 1080/50p	10 bit 4:2:2 Y/Cb/Cr					○*2	○	
	1920 x 1080/60p*1					○*2	○		
	2048 x 1080/24PsF*1*3		10 bit/12 bit 4:4:4 RGB 12 bit 4:4:4 XYZ					○*2	○
	2048 x 1080/24p*1*3						○*2	○	
	2048 x 1080/25PsF*3						○*2	○	
	2048 x 1080/25p*3						○*2	○	
	2048 x 1080/30PsF*1*3					○*2	○		
2048 x 1080/30p*1*3					○*2	○			
3G-SDI	1920 x 1080/24PsF*1	10 bit 4:4:4 Y/Cb/Cr, RGB 12 bit 4:4:4 Y/Cb/Cr, RGB	○*4				○*4		
	1920 x 1080/25PsF		○*4			○*4			
	1920 x 1080/30PsF*1		○*4			○*4			
	1920 x 1080/24p*1		○*4			○*4			
	1920 x 1080/25p		○*4			○*4			
	1920 x 1080/30p*1		○*4			○*4			
	1920 x 1080/50i	10 bit 4:2:2 Y/Cb/Cr	○				○		
	1920 x 1080/60i*1		○			○			
	1920 x 1080/50p		10 bit 4:4:4 Y/Cb/Cr, RGB	○*4				○*4	
	1920 x 1080/60p*1			○*4			○*4		
	1280 x 720/24p*1			○*4			○*4		
	1280 x 720/25p			○*4			○*4		
	1280 x 720/30p*1	○*4				○*4			
	1280 x 720/50p	○*4				○*4			
	1280 x 720/60p*1	10 bit/12 bit 4:4:4 RGB 12 bit 4:4:4 XYZ	○*4				○*4		
	2048 x 1080/24PsF*1*3		○*4			○*4			
	2048 x 1080/24p*1*3		○*4			○*4			
	2048 x 1080/25PsF*3		○*4			○*4			
2048 x 1080/25p*3	○*4				○*4				
2048 x 1080/30PsF*1*3	○*4				○*4				
2048 x 1080/30p*1*3	○*4			○*4					

*1 Also compatible with 1/1.001 frame rates.
 *2 Two BKM-243HS or BKM-244CC are used.
 *3 Supported with the BVM-E250A and BVM-E170A only.
 *4 Untested.

BVM-E / BVM-F Series HDMI and DisplayPort Input Signal Formats

System	Interface sampling frequency [MHz]	Aspect ratio	Standard	HDMI	DisplayPort
				RGB 4:4:4 8/10/12 bit Y/Cb/Cr 4:4:4 8/10/12 bit Y/Cb/Cr 4:2:2 12 bit	RGB 4:4:4 6/8/10 bit Y/Cb/Cr 4:4:4 6/8/10 bit Y/Cb/Cr 4:2:2 12 bit
Video Signals					
640 x 480/60p*1	25.200*1	4:3	CEA-861	○	○
720 x 480/60p*1	27.027*1	4:3/16:9		○	○
1280 x 720/60p*1	74.250*1	16:9		○	○
1920 x 1080/60i*1	74.250*1	16:9	CEA-861	○	○
		2.39:1			
720 (1440) x 480/60i*1	27.027*1	4:3/16:9	CEA-861	○	-
720 x 576/50p	27.000	4:3/16:9		○	○
1280 x 720/50p	74.250	16:9		○	○
1920 x 1080/50i	74.250	16:9	CEA-861	○	○
		2.39:1			
720 (1440) x 576/50i	27.000	4:3/16:9	CEA-861	○	-
1920 x 1080/60p*1	148.500*1	16:9	CEA-861	○	○
		2.39:1			
1920 x 1080/50p	148.500	16:9	CEA-861	○	○
		2.39:1			
1920 x 1080/24p*1	74.250*1	16:9	CEA-861	○	○
		2.39:1			
1920 x 1080/25p	74.250	16:9	CEA-861	○	○
		2.39:1			
1920 x 1080/30p*1	74.250*1	16:9	CEA-861	○	○
		2.39:1			
2048 x 1080/24p*1*2	74.250*1	1.896:1		○	○
		2.39:1			
2048 x 1080/25p*2	74.250	1.896:1		○	○
		2.39:1			
2048 x 1080/30p*1*2	74.250*1	1.896:1		○	○
		2.39:1			
2048 x 1080/60p*1*2	148.500*1	1.896:1		○	○
		2.39:1			
2048 x 1080/50p*2	148.500	1.896:1		○	○
		2.39:1			
2048 x 1080/48p*1*2	148.500*1	1.896:1		○	○
		2.39:1			
Computer Signals					
800 x 600/60p	40.000	4:3	VESA	○	○
1024 x 768/60p	65.000	4:3		○	○
1280 x 960/60p	108.000	4:3		○	○
1280 x 1024/60p	108.000	5:4		○	○
1400 x 1050/60p	121.750	4:3		○	○

*1 Also compatible with 1/1.001 frame rates.

*2 Supported with the BVM-E250A and BVM-E170A only.

Specifications

	BVM-E250A	BVM-E170A
Picture Performance		
Panel	OLED panel	
Picture size (diagonal)	623.4 mm (24 5/8 inches)	419.7 mm (16 1/2 inches)
Effective picture size (H x V)	543.4 x 305.6 mm (21 1/2 x 12 1/8 inches)	365.8 x 205.7 mm (14 1/2 x 8 1/8 inches)
Resolution (H x V)	1920 x 1080 pixels (Full HD)	
Aspect	16:9	
Pixel efficiency	99.99%	
Panel drive	RGB 10-bit	
Panel frame rate	48 Hz / 50 Hz / 60 Hz / 72 Hz / 75 Hz (48 Hz, 60 Hz, and 72 Hz are also compatible with 1/1.001 frame rates)	
Viewing angle (panel specification)	89°/89°/89°/89° (typical) (up/down/left/right contrast > 10:1)	
Color temperature	D55, D61, D65, D93, D-Cine, and user	
Standard luminance	100 cd/m ² (preset1 to preset5) 48 cd/m ² (preset (D-Cine)) (100% white signal input)	
Color space (color gamut)	ITU-R BT.709, EBU, SMPTE-C, D-Cine*1, E250A / E170A Native*2, S-GAMUT*3 The BVM-E250A / BVM-E170A individual chromaticity points: R (x = 0.681, y = 0.319) / G (x = 0.189, y = 0.724) / B (x = 0.141, y = 0.051) (typical)	
Input		
SDI	BNC (x2)	
HDMI	HDMI (x1) (HDCP correspondence, Deep Color correspondence)	
DisplayPort	DisplayPort connector (x1)	
Option port	4 ports	
Parallel remote	D-sub 9-pin (female) (x1)	
Serial remote (LAN)	Ethernet (10BASE-T/100BASE-TX), RJ-45 (x1)	
Output		
SDI	BNC (x1)	
DC 5 V out	Circle 4-pin (female) (x1)	
General		
Power requirement	AC 100 V to 240 V, 1.6 A to 0.8 A, 50/60 Hz	AC 100 V to 240 V, 1.2 A to 0.7 A, 50/60 Hz DC 24 V to 28 V, 4.5 A to 3.9 A
Power consumption	Approx. 145 W (max.) Approx. 72 W (average power consumption in the default status)	Approx. 110 W (AC), 100 W (DC) (max.) Approx. 60 W (AC), 60 W (DC) (average power consumption in the default status)
Operating temperature	0°C to 35°C (32°F to 95°F) Recommended: 20°C to 30°C (68°F to 86°F)	
Operating humidity	0% to 90% (no condensation)	
Storage and transport temperature	-20°C to +60°C (-4°F to +140°F)	
Storage and transport humidity	0% to 90%	
Operating, storage, and transport pressure	700 hPa to 1060 hPa	
Dimensions (W x H x D)	576.0 x 424.0 x 148.0 mm (22 3/4 x 16 3/4 x 5 7/8 inches)	436.0 x 282.4 (266.4)*4 x 214.7 mm (17 1/4 x 11 1/4 (10 1/2)*4 x 8 1/2 inches)
Mass	13.0 kg (28 lb 11 oz)	8.6 kg (18 lb 15 oz)
Supplied accessories	AC power cord (1), AC plug holder (1), Bracket (1), Operation Manual (Japanese, English, each 1), CD-ROM (1), Using the CD-ROM Manual (1)	AC power cord (1), AC plug holder (1), Rack mount bracket (left, right, each 1), Rack mount attachment screws (4), Operation Manual (Japanese, English, each 1), CD-ROM (1), Using the CD-ROM Manual (1)

*1 Chromaticity point of SMPTE RP431-2 is not covered in full.

*2 The widest color space setting of the signal reproduced by the BVM-E250A and BVM-E170A.

*3 S-GAMUT is available for displaying the color gamut of the wide color space mode S-GAMUT, which is offered with the F23 and F35 Digital cinematography cameras.

*4 Height without monitor feet.

	BVM-F250A	BVM-F170A
Picture Performance		
Panel	OLED panel	
Picture size (diagonal)	623.4 mm (24 5/8 inches)	419.7 mm (16 1/2 inches)
Effective picture size (H x V)	543.4 x 305.6 mm (21 1/2 x 12 1/8 inches)	365.8 x 205.7 mm (14 1/2 x 8 1/8 inches)
Resolution (H x V)	1920 x 1080 pixels (Full HD)	
Aspect	16:9	
Pixel efficiency	99.99%	
Panel drive	RGB 10-bit	
Panel frame rate	48 Hz / 50 Hz / 60 Hz / 72 Hz / 75 Hz (48 Hz, 60 Hz, and 72 Hz are also compatible with 1/1.001 frame rates)	
Viewing angle (panel specification)	89°/89°/89°/89° (typical) (up/down/left/right contrast > 10:1)	
Color temperature	D65, D93, and user	
Standard luminance	100 cd/m ² (Preset1 to Preset5) (100% white signal input)	
Color space (color gamut)	ITU-R BT.709, EBU, SMPTE-C, F250A / F170A Native*1 The BVM-F250A / BVM-F170A individual chromaticity points: R (x = 0.681, y = 0.319) / G (x = 0.189, y = 0.724) / B (x = 0.141, y = 0.051) (typical)	
Input		
SDI	BNC (x2)	
HDMI	HDMI (x1) (HDCP correspondence, Deep Color correspondence)	
DisplayPort	DisplayPort connector (x1)	
Option port	4 ports	
Parallel remote	D-sub 9-pin (female) (x1)	
Serial remote (LAN)	Ethernet (10BASE-T/100BASE-TX), RJ-45 (x1)	
Output		
SDI	BNC (x1)	
DC 5 V out	Circle 4-pin (female) (x1)	
General		
Power requirement	AC 100 V to 240 V, 1.6 A to 0.8 A, 50/60 Hz	AC 100 V to 240 V, 1.2 A to 0.7 A, 50/60 Hz DC 24 V to 28 V, 4.5 A to 3.9 A
Power consumption	Approx. 145 W (max.) Approx. 72 W (average power consumption in the default status)	Approx. 110 W (AC), 100 W (DC) (max.) Approx. 60 W (AC), 60 W (DC) (average power consumption in the default status)
Operating temperature	0°C to 35°C (32°F to 95°F) Recommended: 20°C to 30°C (68°F to 86°F)	
Operating humidity	0% to 90% (no condensation)	
Storage and transport temperature	-20°C to +60°C (-4°F to +140°F)	
Storage and transport humidity	0% to 90%	
Operating, storage, and transport pressure	700 hPa to 1060 hPa	
Dimensions (W x H x D)	576.0 x 424.0 x 148.0 mm (22 3/4 x 16 3/4 x 5 7/8 inches)	436.0 x 282.4 (266.4)*2 x 214.7 mm (17 1/4 x 11 1/4 (10 1/2))*2 x 8 1/2 inches)
Mass	13.0 kg (28 lb 11 oz)	8.6 kg (18 lb 15 oz)
Supplied accessories	AC power cord (1), AC plug holder (1), Bracket (1), Operation Manual (Japanese, English, each 1), CD-ROM (1), Using the CD-ROM Manual (1)	AC power cord (1), AC plug holder (1), Rack mount bracket (left, right, each 1), Rack mount attachment screws (4), Operation Manual (Japanese, English, each 1), CD-ROM (1), Using the CD-ROM Manual (1)

*1 The widest color space setting of the signal reproduced by the BVM-F250A and BVM-F170A.

*2 Height without monitor feet.

	PVM-A250	PVM-A170	PVM-741
Picture Performance			
Panel	OLED panel		
Picture size (Diagonal)	623.4 mm (24 5/8 inches)	419.7 mm (16 1/2 inches)	188.0 mm (7 1/2 inches)
Effective picture size (H x V)	543.4 x 305.6 mm (21 1/2 x 12 1/8 inches)	365.8 x 205.7 mm (14 1/2 x 8 1/8 inches)	163.9 x 92.2 mm (6 1/2 x 3 5/8 inches)
Resolution (H x V)	1920 x 1080 pixels (Full HD)	1920 x 1080 pixels (Full HD)	960 x 540 pixels (Quarter HD)
Aspect	16:9		
Panel drive	RGB 10-bit		
Viewing angle (Panel specification)	89°/89°/89°/89° (typical) (up/down/left/right contrast > 10:1)		
Input			
Composite input	BNC (x1), 1.0 Vp-p ±3dB sync negative		
SDI input	BNC (x2)		
HDMI input	HDMI (x1) (HDCP correspondence)		
Audio input	Stereo mini jack (x1), -5 dBu 47 kΩ or higher		
Parallel remote	RJ-45 modular connector 8-pin (x1) (Pin-assignable)		
Serial remote (LAN)	RJ-45 modular connector (x1) (Ethernet, 10BASE-T/100BASE-TX)		
DC input	-	XLR-type 4-pin (male) (x1) DC 12 V to 16 V (output impedance 0.05 Ω or less)	XLR-type 4-pin (male) (x1) DC 12 V (output impedance 0.05 Ω or less)
Output			
Composite output	BNC (x1), Loop-through, with 75 Ω automatic termination		
SDI output	BNC (x2)		BNC (x1)
	Output signal amplitude: 800 mVp-p ±10% Output impedance: 75 Ω unbalanced		
Audio monitor output	Stereo mini jack (x1)		
Speaker (built-in) output	1.0 W (mono)		0.5 W (mono)
Headphone output	Stereo mini jack (x1)		
General			
Power requirements	AC 100 V to 240 V, 1.3 A to 0.6 A, 50/60 Hz	AC 100 V to 240 V, 0.9 A to 0.5 A, 50/60 Hz DC 12 V to 16 V, 6.4 A to 4.8 A	AC 100 V to 240 V, 0.5 A to 0.3 A, 50/60 Hz DC 12 V, 1.9 A
Power consumption	Approx. 115 W (max.) Approx. 80 W (average power consumption in the default status)	Approx. 75 W (AC power supply) (max.) Approx. 60 W (AC power supply) (average power consumption in the default status)	Approx. 30 W (max.) -
Operating temperature	0°C to 35°C (32°F to 95°F) Recommended: 20°C to 30°C (68°F to 86°F)		0°C to 40°C (32°F to 104°F) Recommended: 20°C to 30°C (68°F to 86°F)
Operating humidity	30% to 85% (no condensation)		
Storage / Transport temperature	-20°C to +60°C (-4°F to +140°F)		
Storage / Transport humidity	0% to 90%		
Operating / Storage / Transport pressure	700 hPa to 1060 hPa		
Dimensions (W x H x D)	581.0 x 386.6 x 65.5 mm* (22 7/8 x 15 1/4 x 2 5/8 inches) (without monitor feet) 581.0 x 409.1 x 165.0 mm (22 7/8 x 16 1/8 x 6 1/2 inches) (with monitor feet)	435.0 x 274.0 x 65.5 mm* (17 1/4 x 10 7/8 x 2 5/8 inches) (without monitor feet) 435.0 x 296.5 x 165.0 mm (17 1/4 x 11 3/4 x 6 1/2 inches) (with monitor feet)	222.4 x 166 x 70 mm (8 7/8 x 6 5/8 x 2 7/8 inches) 222.4 x 183.5 x 161.8 mm (8 7/8 x 7 1/4 x 6 3/8 inches) (when AC adaptor is installed)
Mass	Approx. 6.1 kg (13 lb 7.2 oz)	Approx. 4.2 kg (9 lb 4.2 oz)	Approx. 2.0 kg (4 lb 6 oz) Approx. 2.6 kg (5 lb 12 oz) (when AC adaptor is installed)
Supplied accessories	AC power cord (1), AC plug holder (1), Before Using This Unit (1), CD-ROM (1)	AC power cord (1), AC plug holder (1), Handle (1) (including 4 screws), Before Using This Unit (1), CD-ROM (1)	AC power cord (1), AC plug holder (1), AC adaptor (1), Handle (1), Arm mount bracket (1), Screws (4), Operating instructions (1), CD-ROM (1), Using the CD-ROM Manual (1)
Optional accessories	SU-561 Monitor Stand, BKM-PP25 Protection kit	SU-561 Monitor Stand, MB-P17 Mounting bracket, BKM-PP17 Protection kit	MB-531 Mounting bracket, MB-532 Mounting panel, VF-510 Monitor ENG kit

* Without projection parts.

BKM-16R

INPUT/OUTPUT	
LAN	10BASE-T/100BASE-TX connector: RJ-45 (x1)
DC 5V / 12V IN	Circle 4-pin (male) (x1)
GENERAL	
Power requirements	DC IN: 5 V, 1.1 A (supplied by the connected monitor) DC IN: 12 V, 0.5 A (supplied by the connected AC adaptor) AC adaptor: AC IN: 100 V to 240 V, 50/60 Hz, DC OUT: 12 V, 3 A
Current consumption	5 V DC, 1.1 A / 12 V DC, 0.5 A
Power consumption	Approx. 6 W
Operating temperature	0°C to 35°C (32°F to 95°F), Recommended: 20°C to 30°C (68°F to 86°F)
Operating humidity	0% to 90% (no condensation)
Operating pressure	700 hPa to 1060 hPa
Storage and trans. temperature	-10°C to +40°C (14°F to 104°F)
Storage and trans. humidity	0% to 90%
Storage and trans. pressure	700 hPa to 1060 hPa
Dimensions (W x H x D)	424 x 58.8 x 174.9 mm (16 3/4 x 2 3/8 x 7 inches)
Mass	2.1 kg (4 lb 10 oz)
Supplied accessories	AC adaptor (1), AC power cord (parts number: 1-757-562-1x1 for USA and Canada, 1-575-131-8x for Europe) (1), Rack mount brackets (2), Rack mount attachment screws (4), Function labels (2), Operation manual (1)

PVM-A250 / PVM-A170 / PVM-741 Signal Formats

System	Signal standard				HDMI
	Analog composite	SD/HD	SDI Dual link *5	3G	
575/50i (PAL)	○	○	–	–	○
480/60i (NTSC)*1	○	○	–	–	○
576/50p	–	–	–	–	○
480/60p*1	–	–	–	–	○
640 x 480/60p*1	–	–	–	–	○
1920 x 1080/24PsF*1*2	–	○	○*3	○*3	–
1920 x 1080/25PsF*2	–	○	○*3	○*3	–
1920 x 1080/30PsF*1*2	–	○*5	○*3	○*3	–
1920 x 1080/24p*1	–	○	○*3	○*3	○
1920 x 1080/25p	–	○	○*3	○*3	○
1920 x 1080/30p*1	–	○	○*3	○*3	○
1920 x 1080/50i	–	○	○*3	○*3	○
1920 x 1080/60i*1	–	○	○*3	○*3	○
1920 x 1080/50p	–	–	○*4	○*4	○
1920 x 1080/60p*1	–	–	○*4	○*4	○
1280 x 720/24p*1	–	○	–	–	–
1280 x 720/25p	–	○	–	–	–
1280 x 720/30p*1	–	○	–	–	–
1280 x 720/50p	–	○	–	○*3	○
1280 x 720/60p*1	–	○	–	○*3	○
2048 x 1080/24PsF*1*2*5	–	○	○*3	○*3	–
2048 x 1080/25PsF*2*5	–	○	○*3	○*3	–
2048 x 1080/30PsF*1*2*5	–	○	○*3	○*3	–
2048 x 1080/24p*1*5	–	○	○*3	○*3	–
2048 x 1080/25p*5	–	○	○*3	○*3	–
2048 x 1080/30p*1*5	–	○	○*3	○*3	–
2048 x 1080/48p*1*5	–	–	○*4	○*4	–
2048 x 1080/50p*5	–	–	○*4	○*4	–
2048 x 1080/60p*1*5	–	–	○*4	○*4	–

*1 Compatible with 1/1,001 frame rates.

*2 PVM-A Series: 1080/25PsF, 30PsF, 2048/25PsF, 30PsF are displayed as 1080/25PsF, 30PsF, 2048/25PsF, 30PsF on the screen if the Payload ID is added to the video signal, or displayed as 1080/50i, 60i, 2048/50i, 60i if the ID is not added.
PVM-741: 1080/24PsF, 25PsF, and 30PsF are displayed as 1080/48i, 50i, and 60i on the screen, respectively.

*3 10-bit 4:4:4 Y/C_B/C_R and 4:4:4 RGB are supported.

*4 10-bit 4:2:2 Y/C_B/C_R is supported.

*5 PVM-A250/PVM-A170 only support 1920 x 1080/30PsF, the dual link and 2048 signals.

Dimensions

Unit: mm (inches)

BVM-E250A / BVM-F250A

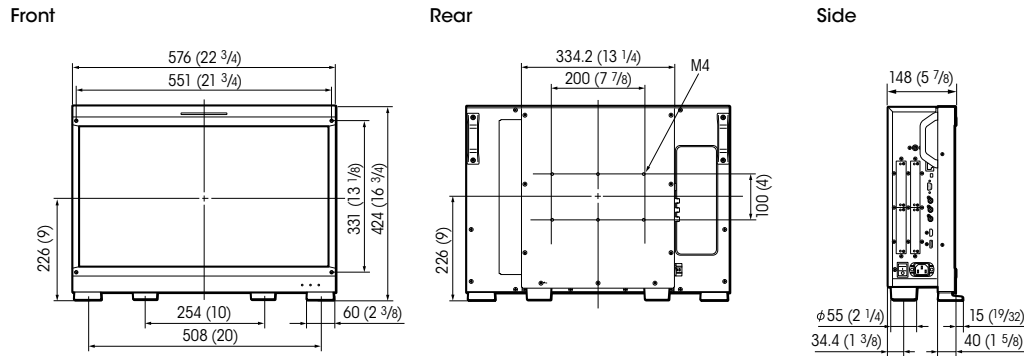

BVM-E250A / BVM-F250A with the optional BKM-16R and BKM-37H with a tilt

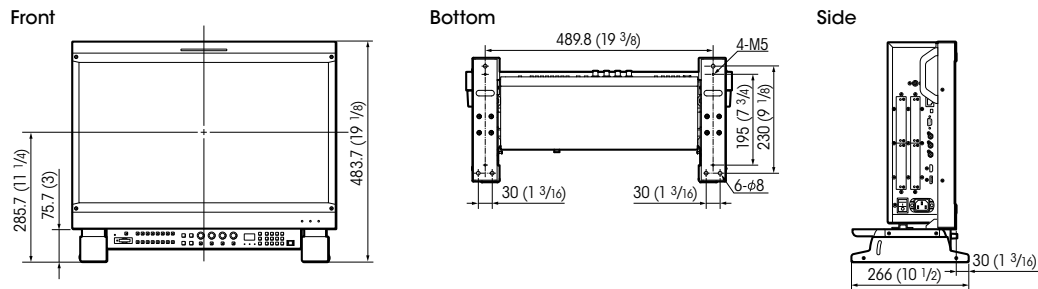

BVM-E250A / BVM-F250A with the optional BKM-16R and BKM-38H

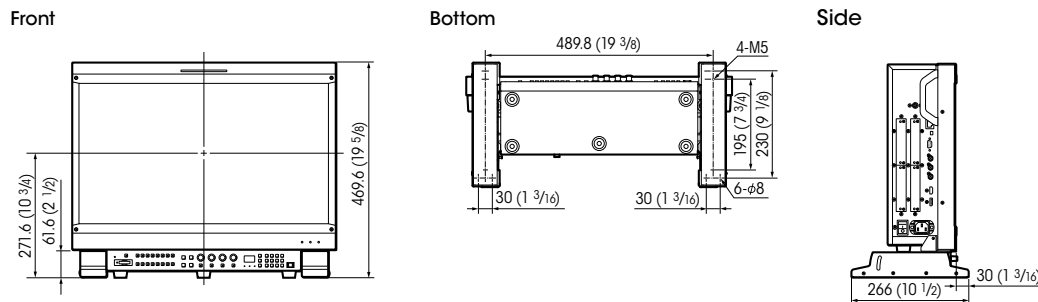

BVM-E170A / BVM-F170A

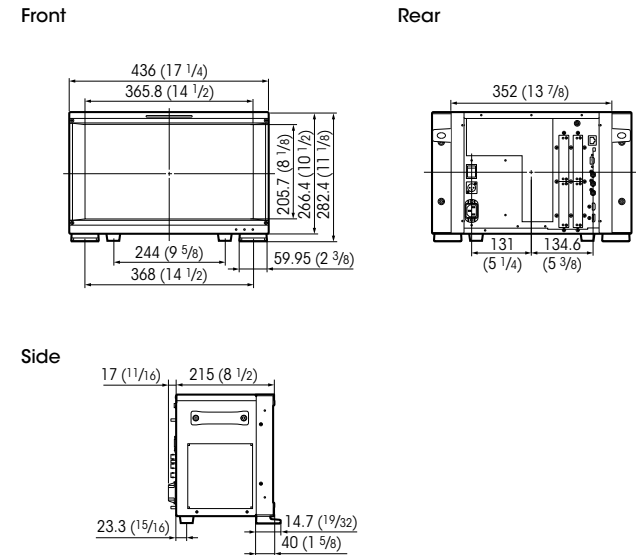

BVM-E170A / BVM-F170A with the optional BKM-16R and BKM-39H

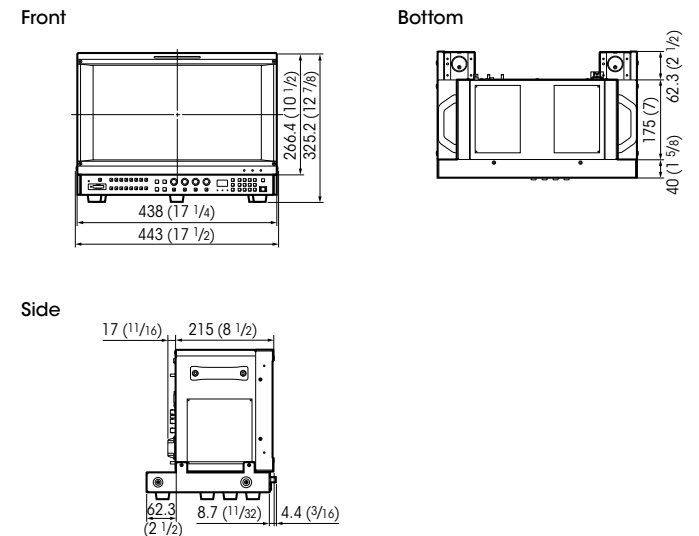

PVM-A250

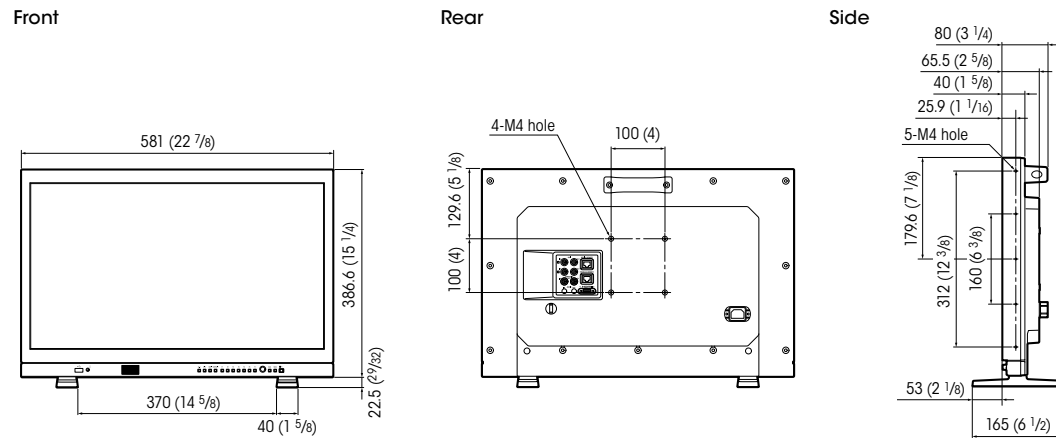

BKM-16R

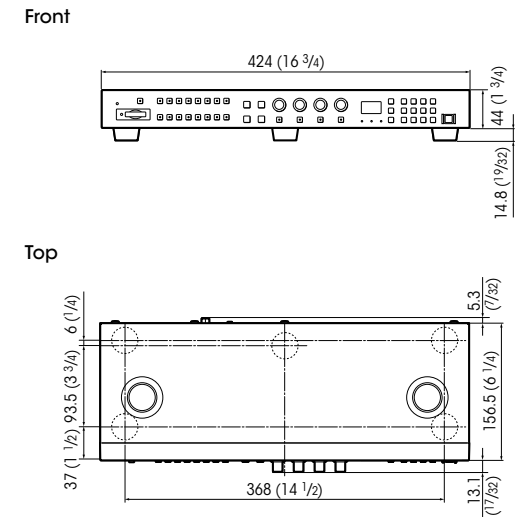

PVM-A170

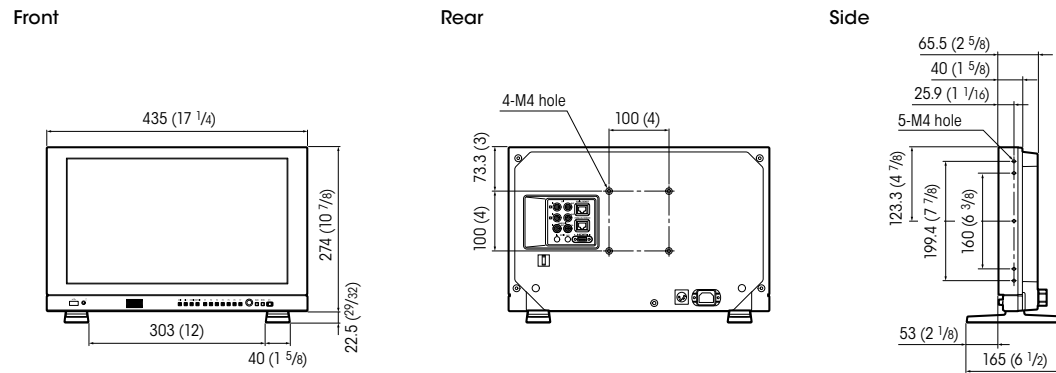

PVM-741

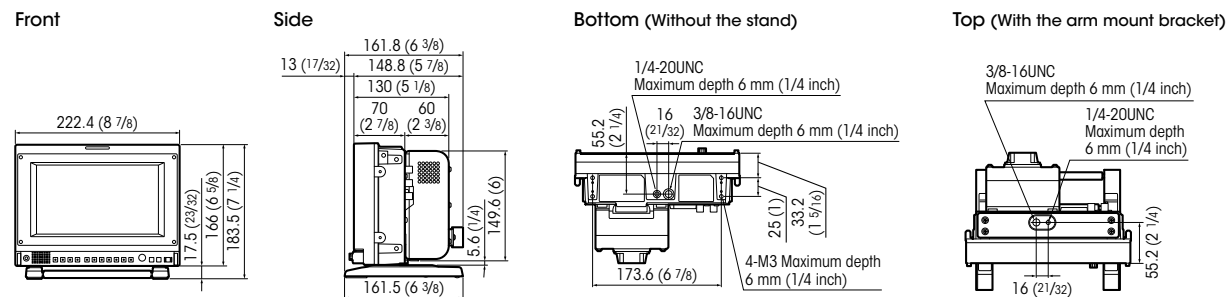

Options

For BVM-E250A, BVM-E170A, BVM-F250A, and BVM-F170A



BKM-16R*1
Monitor Control Unit



BKM-250TG
3G/HD/SD-SDI Input Adaptor



BKM-244CC
HD/SD-SDI Closed Caption Adaptor



BKM-243HS
HD/SD-SDI Input Adaptor



BKM-220D
SD-SDI 4:2:2 Input Adaptor



BKM-229X
Analog Component Adaptor



BKM-227W
NTSC/PAL Input Adaptor



BKM-37H*2
Controller Attachment Stand with tilt



BKM-38H*2
Controller Attachment Stand



BKM-39H*2
Controller Attachment Stand



SMF-700
Monitor Interface Cable

For PVM-A250 and PVM-A170



SU-561
Monitor stand



BKM-PP25
Protection kit (for PVM-A250)



BKM-PP17
Protection kit (for PVM-A170)



MB-P17
Mounting bracket (for PVM-A170)



MB-L22
Mounting bracket (for PVM-A250)

For PVM-741



MB-531
Mounting Bracket



MB-532
Mounting Panel



VF-510
ENG Kit (Viewing Hood, Carrying Handle and Connector Protector)

*1 Requires the latest version of the BKM-16R with a product code suffix /7 or later.

*2 Requires the latest version of the BKM-37H, BKM-38H, and BKM-39H with a product code suffix /1 or later.

Distributed by

MK11127V1Y14MAR

©2014 Sony Corporation. All rights reserved.

Reproduction in whole or in part without written permission is prohibited.

Features and specifications are subject to change without notice.

Screen images are simulated.

The values for mass and dimension are approximate.

"SONY", "TRIMASTER", "TRIMASTER EL", "ChromaTRU", "Memory Stick", "Memory Stick PRO", "Memory Stick Duo",

"Memory Stick PRO Duo", and "Memory Stick Micro" are trademarks of Sony Corporation.

HDMI is a trademark of HDMI Licensing, LLC.

All other trademarks are the properties of their respective owners.

The BVM-E250A, BVM-E170A, BVM-F250A, BVM-F170A, PVM-A250, and PVM-A170 are produced at Sony EMCS Corporation Kosai Site, which has received ISO14001 Environmental Management System certification.

